



ELSEVIER

Available online at www.sciencedirect.com

SCIENCE @ DIRECT®

International Journal of Multiphase Flow 31 (2005) 514–528

International Journal of
**Multiphase
Flow**

www.elsevier.com/locate/ijmulflow

The split of stratified gas–liquid flow at a small diameter T-junction

G. Das ^{a,b}, P.K. Das ^{a,c}, B.J. Azzopardi ^{a,*}

^a *Multiphase Flow Research Group, Nottingham Fuel and Energy Centre, School of Chemical, Environmental and Mining Engineering, University of Nottingham, University Park, Nottingham NG7 2RD, UK*

^b *Department of Chemical Engineering, Indian Institute of Technology, Kharagpur 721302, India*

^c *Department of Mechanical Engineering, Indian Institute of Technology, Kharagpur 721302, India*

Received 18 February 2004; received in revised form 25 January 2005

Abstract

The present work reports a study of phase split at a horizontal T-junction with main and side branches of 0.005 m diameters. The experiments were confined to the stratified flow pattern and the effects of phase velocities and pressure on the split were examined. The results were also compared with those reported for larger T-junctions. The side arm take-off tends to be richer in the gas phase with increase in pressure under all flow conditions. The reason has been attributed to the complex effect of pressure on the interface position (characterised by the dimensionless liquid height, h/D) which in turn determines the gas and liquid momentum.

© 2005 Elsevier Ltd. All rights reserved.

Keywords: Gas/liquid; T-junction; Phase separation; Small diameter; Horizontal

1. Introduction

Two-phase flow through T-junctions is most often characterised by a maldistribution of the phases between the outlets. Apart from being a topic of fundamental interest, this phenomenon

* Corresponding author. Tel.: +44 115 951 4160; fax: +44 115 951 4115.

E-mail address: barry.azzopardi@nottingham.ac.uk (B.J. Azzopardi).

is of significant technical concern. The maldistribution in the downstream equipment can cause major problems in operation and control of the process and power industries as well as in oil and gas production. On the other hand, one may take advantage of it to build compact and comparatively inexpensive separators for the partial separation of gas–liquid mixtures (Azzopardi, 1993; Azzopardi et al., 2002).

Over the last two decades, numerous efforts have been made to study the phenomenon of phase separation through T-junctions both by experimental investigation and theoretical analysis. The problem has also been addressed in several state of the art reviews, e.g., Azzopardi and Hervieu (1994), Lahey (1986), Muller and Reimann (1991) and Azzopardi (1999). The research effort has shown that in general the prediction of flow distribution is difficult due to the complexity of the flow phenomenon. It is also an established fact that the orientation of the junction and the flow pattern approaching it largely influences the flow separation. Keeping relevance to the present work, the discussion is mainly focussed to stratified flow through T-junctions with horizontal main and side arms.

One of the earliest works relevant to the present study was that of Hong (1978). He performed extensive experiments through a horizontal T-junction of 9.525 mm diameter. He studied the effect of varying phase velocities and liquid viscosity for stratified wavy and annular flow patterns at the inlet. He reported that the fraction of liquid taken off increases with increasing gas and decreasing liquid velocity. It was suggested that the liquid taken off is governed by the competing centripetal force exerted by the gas phase due to an abrupt change in its direction and the inertial force of the liquid. This is in agreement to the suggestion of Oranje (1973).

Shoham et al. (1987) used a larger diameter (50 mm) T-junction and noted the inlet flow pattern to exert a strong influence on the splitting phenomena. Although they obtained trends similar to Hong and Oranje, their data gave a higher liquid take off than Hong at a low gas take off while a lower liquid take off at a higher gas take off. They further proposed a flow pattern specific model to predict the flow splitting for the stratified and the annular flow patterns. Subsequently, Penmat-cha et al. (1996) and Marti and Shoham (1997) have extended the model to calculate flow splits in T-junctions with inclined and reduced side arms.

Azzopardi and Memory (1989) investigated phase split for wavy stratified and annular flow patterns for a junction with a main pipe diameter of 38 mm. They performed experiments with both equal diameter and reduced arm T-junctions at pressures of 150 and 300 kPa. They postulated the change in the slope of the take-off curves to be a function of phase momentum flux. They further performed an experiment with same liquid but two different gas velocities at different pressures to maintain identical superficial momentum of the gas for both the cases. The identical phase split curves for the two cases once again demonstrated the importance of momentum on the splitting phenomena.

Hart et al. (1991) proposed a “Double Stream Model” to predict the preference of liquid route during separated gas–liquid flow through horizontal main and side arms. The model was primarily applicable for low liquid holdup ($\varepsilon_L < 0.06$). According to the model, the mass of liquid diverted through the branch is a function of gas mass intake fraction, geometry of the junction and the ratio of the kinetic energy per unit volume of inlet gas and liquid flow. The authors reported a good agreement with the experimental results over a wide range of transport properties and superficial phase velocities for both regular and reduced T-junctions. Subsequently, Ottens et al. (1995) had extended the model by relaxing some of the original assumptions.

Buell et al. (1994) have reported experimental data for phase distribution and junction pressure drops of low-pressure air-water mixtures through a horizontal 37.6 mm T-junction. The upstream flow patterns corresponded to stratified, wavy, slug and annular patterns. They also noted a preference of the gas phase to exit through the branch at increased liquid velocity. The high-pressure steam/water data of Rubel et al. (1988) also exhibited similar trends.

Peng et al. (1998) have complimented the existing data base on stratified flow through a horizontal T-junction and provided additional split data of steam/water flows through a 76 mm T-junction. Their measurements include the void fraction at the run and branch arms as well as the inlet liquid level for steam and water superficial velocities of 1.5–5 m/s and 0.05–0.09 m/s, respectively. The degree of phase redistribution downstream of the junction was noted to depend on the axial momentum flux, the phase distribution at the inlet as well as the relative branch size and its orientation.

Rea and Azzopardi (2001) reported experimental results for a large diameter (127 mm) T-junction under stratified flow over the entire range of phase velocities from 0.02 to 0.6 m/s for liquid and 4 to 30 m/s for the gas phase. Their take off curves were characterised by three regions: an initial take off region of steepish slope, a central region of gradual slope and a third region of steeper slope. The authors attributed this high initial take off to a dam break type behaviour proposed by Arrichakran (1990) for slug flow and suggested an empirical relationship on the basis of this postulation.

A survey of the past literature shows that the investigations on phase maldistribution through horizontal T-junctions has so far been conducted mostly in large diameter tubes ranging from 9 mm to 127 mm. On the other hand, the conduit size has been noted to influence the flow patterns particularly in horizontal two-phase flow. Barnea et al. (1983) observed a marked difference in the boundary of stratified-slug transition in small diameter (4–12 mm) tubes as compared to large diameters. They have attributed this difference to the effect of surface tension. Small diameter junctions are also of interest due to their applicability in compact chemical plants recently being advocated for the manufacturing of hazardous materials. Studies in small junctions may also contribute to the tests, which are expected to yield a better understanding of the scale up to industrial geometries. Besides, micro channel cooling devices are nowadays being proposed for high heat flux duties. Two-phase flow in the headers of such components can be better perceived through a study of phase redistribution in small diameter T-junctions. Recently, Stacey et al. (2000) have extended the range of diameters (9–127 mm) by presenting experimental data for a T-junction of 5 mm diameter for the annular flow pattern and observed an increased fraction of liquid taken off by decreasing the pipe diameter. They attributed this trend to the lower entrained fraction and more uniform distribution of the film for the smaller pipes. Subsequently, Wren et al. (in press) reported significant differences between the takeoff curves for slug and annular flows for the T-junction of same dimension.

The present study has been undertaken to extend the observations of the above researchers to stratified flow in an equal diameter (5 mm). T-junction with horizontal main and side arms. Efforts have been made to study the influence of phase superficial velocities on the split characteristics under a constant pressure at the T-junction. Additional experiments, at a different pressure, have been conducted to understand the effect of pressure on phase redistribution. The present experimental data have been compared with those reported in literature for large diameter pipes under similar flow conditions to investigate the effect of diameter, if any, on the take off behaviour.

2. Experimental arrangement

The experimental facility used by Stacey et al. (2000) has been modified to suit the present work. Air and demineralised water have been used as the test fluids. As shown schematically in Fig. 1, air drawn from the compressed air main is supplied to a porous wall two-phase mixer where it mixes with the water pumped from a storage tank. Inflow of air and water are metered using separate banks of calibrated rotameters. A horizontal straight developing length of 1.76 m is provided downstream of the mixer before the flow enters the T-junction. The T-junction used in this study is smoothly machined inside a rectangular block of acrylic resin. The transparent block facilitates visualisation while the flat external surface minimises the distortion due to refraction. The two-phase flow from the main outlet and side arm are led through horizontal pipelines of 5 mm diameter and 2 m and 1.5 m straight lengths, respectively, before the pipelines vertically drop to two separators consisting of vertical cylinders of 100 mm diameter. After separation, the liquid is collected from the bottom of the respective separators and air passes out through pipes at the top. Water flow rates from the run and side arms are estimated from volumetric measurements while the airflow rates are measured by wet gas flow meters.

For each pair of phase superficial velocities, the split data has been noted over the entire range of flow split from 0 to 1. This has been accomplished by adjusting the opening of valves in the run and side arms from fully open to fully closed position while ensuring a constant pressure at the T-junction. Pressures of 131.5 and 191 kPa were used. For each test, the flow rates emerging from the run and side arms of the horizontal junction were recorded and the fraction of air and water flow taken off through the side arm was calculated. Liquid flow rate from the side and main arm of the junction was separately collected and measured using volumetric measurement technique. The corresponding gas flow rates were measured by wet gas flow meter.

Utmost care has been taken to reduce the experimental error. A meticulous error analysis has also been done using the methodology suggested by Kline and McClintock (1953) and Moffat

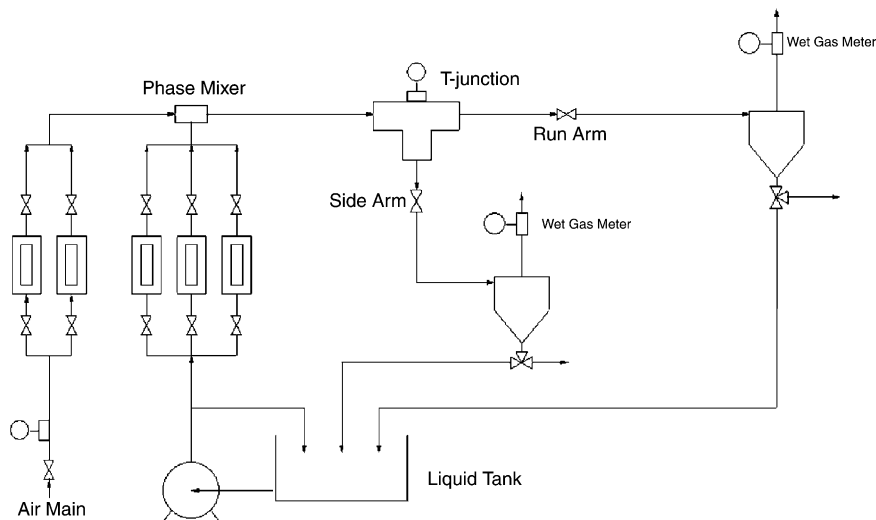

Fig. 1. Schematic diagram of the small diameter two-phase flow loop.

(1982, 1988). The error for the flow rate measurement using the rotameters is within $\pm 3\%$. The volumetric flow rate was measured for a sufficiently long time to avoid personal error. The estimated error in this case was $\pm 1.5\%$. The error in the gas flow rate measurement using the wet gas flow meter was limited to $\pm 2.5\%$. Based on these calculations, the maximum error in phase split calculation was $\pm 5.6\%$. Further, for each point, mass balances were carried out between the inlet and outlet flows. For water, all reported data agree within $\pm 5\%$. The only exception were a few data points at very low take offs which yielded a maximum error of $\pm 7\%$. For air, all data fell within $\pm 9\%$. The reproducibility of the data was tested under identical inlet conditions. No appreciable difference could be discerned between the experiments when the error was restricted to the above limits.

3. Results and discussion

3.1. Flow pattern at the entry to the T-junction

Measurements of phase splits were taken at gas superficial velocities of 2.5 m/s, 3.5 m/s and 5 m/s for water superficial velocities of 0.0055 m/s and 0.0097 m/s and pressures of 131.5 and 191 kPa. The flow has been observed to be smooth stratified for all the cases. To ascertain the observed flow pattern, the experimental data have been plotted on a flow pattern map. The most widely used flow pattern map is due to Taitel and Dukler (1976). On the other hand, Barnea et al. (1983) have pointed out the increased effect of surface tension in small diameter pipes. They have incorporated this effect in the mechanistic model proposed by Taitel and Dukler and obtained the stratified-slug transition to occur at lower liquid velocities. Their experimental data in the range of pipe diameter from 0.004–0.012 m agree well with their modified equations. Since the present study has been performed in a pipe of diameter 5 mm, a flow pattern map based on the equations of Barnea et al. (1983) have been constructed for a 5 mm pipe. The phase velocities of the present work when plotted on the map (in Fig. 2) confirm the flow to be smooth stratified for all the cases.

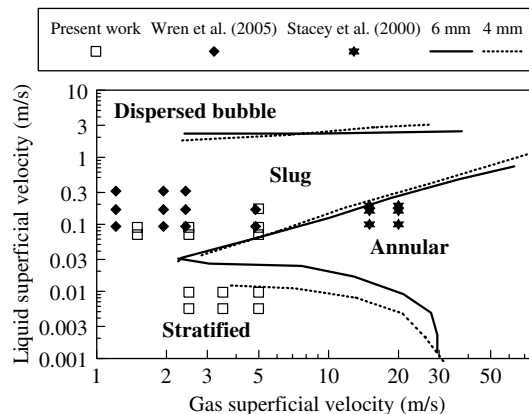

Fig. 2. Flow pattern map of Barnea et al. (1983) for horizontal pipes of 0.005 m diameter showing conditions at which data for phase split at T-junctions has been obtained.

The conditions at which the data of Stacey et al. (2000) and Wren et al. (in press) were taken in the same T junction are also shown.

A survey of the past literature shows that the majority of the split data reported to date in the stratified flow pattern are for phase velocities which do not lie below the stratified/slug boundary in Fig. 2. In order to understand the effect of pipe diameter on phase split for such cases, additional experiments have been conducted at phase flow rates and pressure conditions similar to those reported in literature. These data have been recorded at liquid superficial velocities of 0.07 m/s and 0.09 m/s for gas superficial velocities of 1.5 m/s, 2.5 m/s and 5 m/s at a pressure of 131.5 kPa at the T-junction. These were chosen to be close to the data of Peng et al. (diameter of T-junction = 76 mm) and at liquid superficial velocity of 0.17 m/s and gas superficial velocity of 5 m/s to be similar to experiments by Rea and Azzopardi (2001). The visual observations under these flow conditions reveal some interesting features. From Fig. 2 the data points lie close to the stratified-slug transition or in the slug flow pattern in a narrow pipe but the flow does not appear to exhibit the distinct intermittent characteristic of slug flow. Rather, the flow appears to be stratified with a wave like characteristic of the gas–liquid interface unlike its very smooth appearance at low liquid velocities. The amplitude and frequency of the waves increase with phase velocities and the interface appear to reach the upper wall occasionally at liquid superficial velocity of 0.17 m/s and gas superficial velocity of 5 m/s. This bridging effect might have formed a few intermittent gas plugs but no distinct slug flow was evident. On the other hand, the flow changes to slug by increasing the pressure by 1.5 kPa.

It is felt that the T-junction in this case acts as an abrupt expansion and provides an additional path to both the phases, causing a sudden reduction in their velocity further downstream. Additionally, the gas phase undergoes an expansion due to the availability of larger flow area. This may dampen the incoming water waves and retard the transition to slug flow. To the best of the author's knowledge, no elaborate study has been done to investigate the effect of sudden expansion on the upstream flow pattern in a horizontal conduit. Fossa and Guglielmini (1999) studied the effect of contraction in a horizontal channel on the two-phase intermittent flow. They reported that the flow restriction highly modifies the flow structure upstream and downstream of the discontinuity and promotes the intermittent behaviour of the flow. This seems to justify the present observations.

On the other hand, the increased density of the gas at the higher pressure affects the actual gas and liquid velocity in a complex manner as has been explained at a later section. This is thought to counteract the effect of the T-junction and produce slug flow at the higher pressure. Taitel and Dukler (1976) have also reported the pattern boundaries to occur at lower phase velocities with increase of pressure. It has further been noted that the majority of the past studies on stratified flow through horizontal T-junctions had employed higher pressures at the T-junction. The only work carried out near atmospheric pressure by Rea and Azzopardi (2001), have reported stratified flow much above the transition boundary. Of course, additional factors may have been responsible for the phenomena in their study.

3.2. Effect of phase superficial velocity on phase split

The results thus recorded at 131.5 kPa are represented graphically in Fig. 3(a) and (b). Both the figures bring out the effect of gas and liquid velocity on the redistribution of the two-phases at the

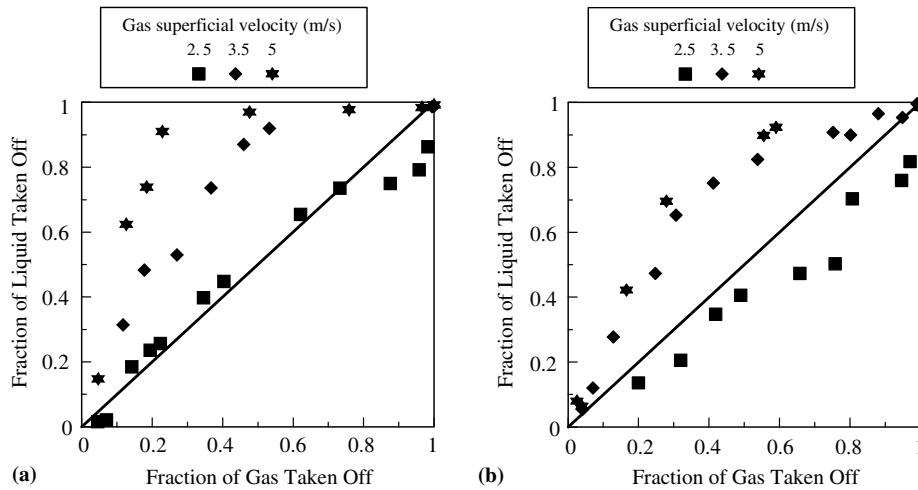

Fig. 3. Effect of gas superficial velocity on phase split at 131.5 kPa and liquid superficial velocities of (a) 0.0055 m/s; (b) 0.0097 m/s.

T-junction. At the lowest gas velocity, the data is observed to lie close to the equal split line for both the liquid velocities and it shifts from a gas rich zone to a liquid rich one with a decrease in liquid velocity. The phase redistribution improves with increase in gas velocity in both the figures with more of the liquid being diverted to the branch with higher gas and lower liquid velocity. The same trends have also been reported by [Shoham et al. \(1987\)](#), [Buell et al. \(1994\)](#) and [Hong \(1978\)](#). They have attributed these trends to the influence of gas and liquid momentum on the flow distribution.

Further, previous researchers had reported that the influence of liquid superficial velocity in an equal diameter T-junction decreases with increase of liquid flow rate. [Azzopardi \(1999\)](#) has shown this feature in an extensive comparison of the data of [Buell et al. \(1994\)](#), [Rea and Azzopardi \(2001\)](#), [Rubel et al. \(1988\)](#) and [Peng et al. \(1998\)](#). However, all the data considered were for pipe diameters from 38 mm to 127 mm. In order to understand the effect in a small diameter T-junction, a comparison of the flow split data over the entire set of liquid flow rates (0.005–0.17 m/s) have been reported in [Fig. 4\(a\)](#) and (b). The figures for constant gas superficial velocity of 2.5 m/s and 5 m/s, respectively, at a T pressure of 131.5 kPa show that the phase split has shifted from liquid rich to gas rich zone with increase of velocity. The same trend is evident from the data of [Hong \(1978\)](#) at gas superficial velocities of 9.14 m/s and 27.52 m/s although the flow pattern changes from stratified way to annular as the liquid flow rate drops from 0.17 m/s to 0.0085 m/s. Moreover, while the influence of liquid velocity is evident for the lowest flow rates, the split data are almost identical for the three higher liquid velocities in [Fig. 4\(a\)](#). The same trend is evident in [Fig. 4\(b\)](#) at a lower gas velocity although the spread in the distribution tends to merge at the lower air velocity. These figures, therefore, seem to confirm the observation of [Azzopardi \(1999\)](#) for large diameter junctions.

[Rea and Azzopardi \(2001\)](#) have reported an interesting feature in the split data obtained from their experiments in horizontal stratified flow. They have noted their take off curves to exhibit three regions—an initial take off with a steeper slope, a central region of gradual slope and a third

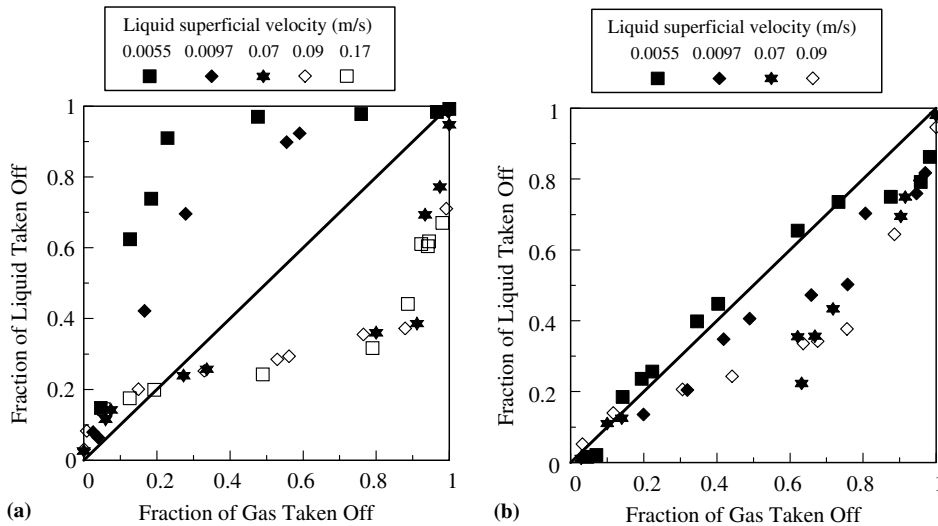

Fig. 4. Effect of liquid superficial velocity on phase split at 131.5 kPa and gas superficial velocities of (a) 4.9 m/s (b) 2.5 m/s.

region of steep slope. They have postulated the initial take off to occur due to dam break phenomena described by Arrichakran (1990) for slug flow. Similar take off curves has also been observed by Azzopardi and Memory (1989). A closer examination of Fig. 4(a) and (b) shows the three regions described by Rea and Azzopardi (2001) in the take off plots at the higher liquid velocities of the present work. This gives a strikingly similar appearance of the split curves of the present work and those reported by Rea and Azzopardi (2001) under similar phase velocities and pressure (Fig. 5). The break point, under these conditions, does not change remarkably with liquid velocity. On the other hand, a decrease in liquid velocity is accompanied by a longer initial take off region followed by a region of moderate slope and a negligible third region. The break point is no longer independent of liquid velocity. It occurs at higher gas take offs for the lower liquid velocity. Such take off curves have not been mentioned by other researchers working on stratified flow through horizontal T-junctions. This is probably due to the lack of experimental data over the whole range of flow split from 0 to 1, particularly at low gas takeoff. Nevertheless, the curves of Penmatcha et al. (1996) and Hong as reported by Azzopardi (1999) show the three regions mentioned above. The break point is evident in the data of Hong (1978) and Oranje (1973). The data of Buell et al. (1994) as represented by Azzopardi (1999) shows the break point to occur at lower gas take offs for higher liquid velocities in agreement to the observations of the present work.

3.3. Effect of pressure on flow split

Further efforts have been made to understand the effect of pressure at the junction on the split of the two-phases. A review of the past literature shows that the majority of the experiments on flow through T-junctions have been carried out at a particular pressure at the T-junction. A systematic study to understand the effect of pressure has rarely been undertaken. A major

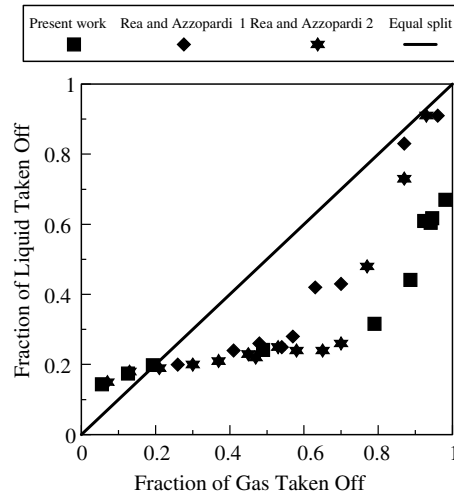

Fig. 5. Comparison of present data with that of Rea and Azzopardi (2001). Present data—pressure = 31.5 kPa, diameter = 0.005 m, liquid superficial velocity = 0.17 m/s, U_{Gs} = 5 m/s. Rea and Azzopardi—diameter = 0.127 m, pressure = 100 kPa, liquid superficial velocity = 0.186 m/s, U_{Gs} = 4 m/s (1), 8 m/s (2).

contribution in this aspect has been made by Azzopardi and Memory (1989) who carefully selected the gas flow rate and system pressure to obtain the same superficial momentum of the gas for identical liquid velocity. The closeness of the takeoff curves under the different sets of flow conditions confirmed the importance of phase superficial momentum on phase split. A recent paper by Van Gorp et al. (2001) on reduced T-junctions has also shown that the pressure at the T-junction does exert an influence on flow split in both the stratified and annular flow patterns. However, they failed to establish a definite trend of the influence and thought the pressure to have a multifold influence on phase redistribution in stratified flow.

In order to understand the effect of pressure on flow split, experiments have been performed under identical phase velocities (liquid superficial velocities of 0.0055 m/s and 0.0097 m/s at gas superficial velocities of 2.5 m/s, 3.5 m/s and 5 m/s) but at a higher pressure of 191 kPa. The take off curves at the higher pressure have been presented in Fig. 6 for the higher liquid velocity in order to avoid repetition. They are similar in nature to those obtained under the low pressure conditions, exhibiting higher liquid take off with higher gas and lower liquid velocity. A comparison of the split data at the two pressures (Fig. 7a–c) indicates that the branch take off tends to be richer in the gas phase with increase of pressure for all the cases. However, the influence tends to be less pronounced at the lower gas flow rate for both the liquid velocities (Fig. 7c). The take off curves shift from a liquid rich to a gas rich region at a gas superficial velocity of 3.5 m/s (Fig. 7b).

At a first glance, it may appear that the effect of pressure is to primarily affect the gas density and momentum without altering the momentum of the incompressible liquid phase. However, the trends reported above denote that in reality, it may also exert an indirect effect on the liquid momentum. In order to understand the influence of pressure, an attempt has been made to calculate the depth, h/D , as well as the momentum and velocity of the individual phases. The Taitel and Dukler (1976) model has been adopted for this purpose. Several researchers have obtained

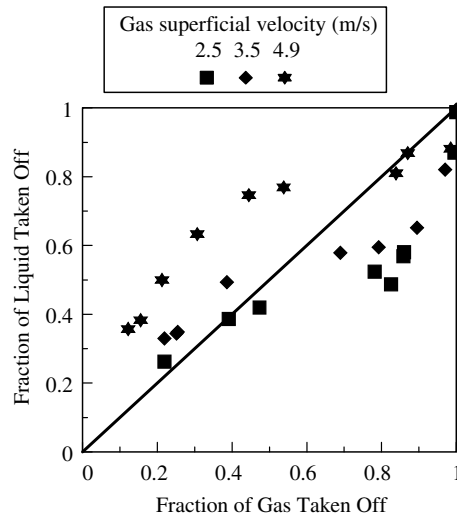

Fig. 6. Effect of gas superficial velocity of phase split at 190.9 kPa and liquid superficial velocity of 0.0097 m/s.

accurate results with this model particularly for the smooth stratified flow. The flow parameters obtained under different phase velocities and pressure conditions have been listed in Table 1. The table shows that an increase in pressure actually reduces the dimensionless height (h/D) for gas superficial velocities of 3.5 m/s and 5 m/s whereas the h/D at a gas superficial velocity of 2.5 m/s is identical for both the pressure conditions. As a result, the actual liquid velocity and momentum flux increases and gas velocity decreases with an increase in pressure at the higher gas velocities. This results in the preferential discharge of the gas phase through the branch. At a gas superficial velocity of 2.5 m/s, an increase in pressure does not have any significant effect on the actual liquid velocity and its momentum flux. This explains the closeness of the split curves with a tendency of liquid rich distribution at a gas superficial velocity of 2.5 m/s and a liquid superficial velocity of 0.0055 m/s. The general trends of the flow split curves and the model predictions for different gas velocities are true for both the liquid flow rates.

Hart et al. (1991) have suggested the liquid split to depend on the velocity profiles of gas and liquid at the inlet beside their densities, flow rates and hold up values. The change in gas velocity profile as the gas flow shifts from laminar to turbulent regime with increase in pressure at a gas superficial velocity of 3.5 m/s probably causes the change in take off characteristics under these flow conditions. It is laminar for a gas superficial velocity of 2.5 m/s and turbulent when the gas superficial velocity is 5 m/s under both the pressure conditions.

The importance of h/D in determining phase distribution during stratified flow through a horizontal T-junction can further be appreciated by considering the data pair of Azzopardi and Memory (1989) in which they have obtained similar take off curves. The Taitel and Dukler model has been used for estimating the flow parameters for the two sets of data at liquid superficial velocity of 0.055 m/s with gas superficial velocity of 8.33 m/s for a pressure of 150 kPa and of 5.88 m/s for 300 kPa. The calculations (as shown in Table 2) have yielded h/D values of 0.171 and 0.172 for the two cases in spite of the large differences in pressure and superficial gas velocity. This reinforces the role of h/D in determining the flow split.

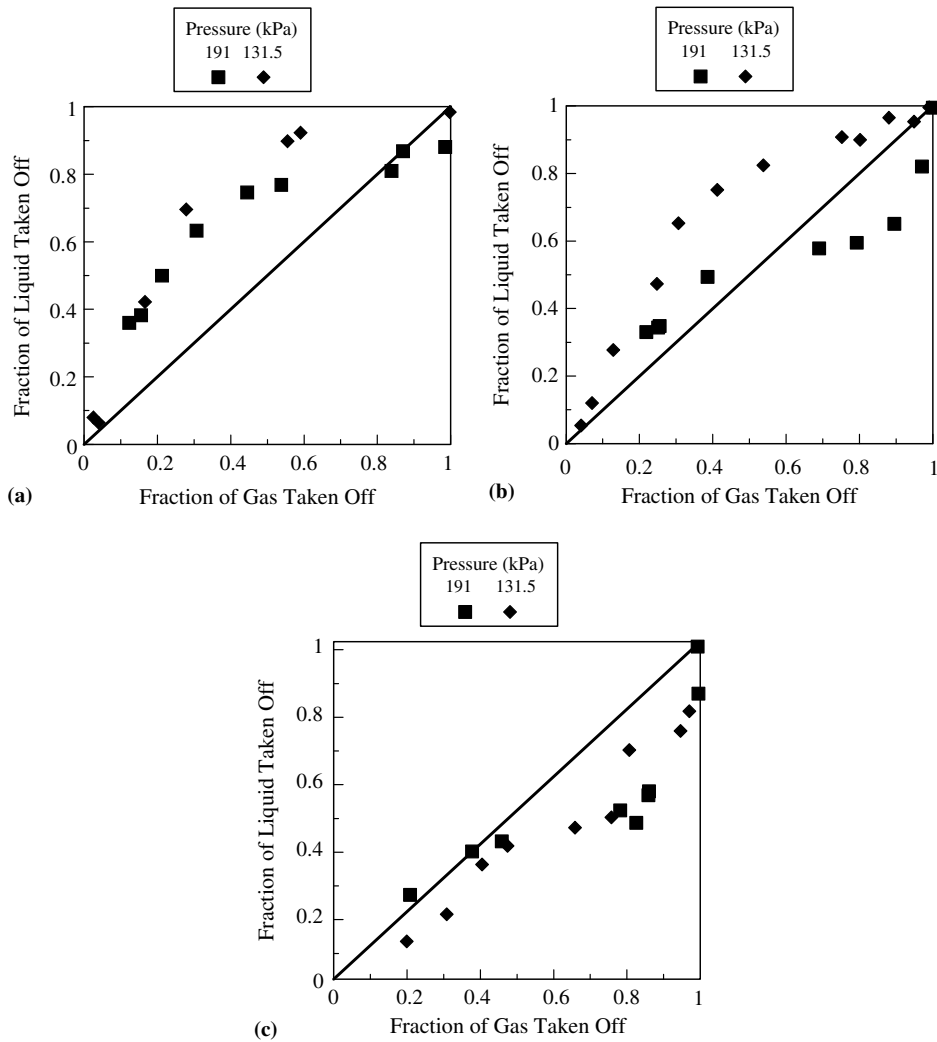

Fig. 7. Effect of pressure on phase split at a liquid superficial velocity = 0.0097 m/s and gas superficial velocity (a) 4.9 m/s, (b) 3.5 m/s and (c) 2.5 m/s.

3.4. Comparison with data from literature in large diameter pipes

The present experimental data has been compared with the data available in literature in large diameter pipes in order to understand the influence of pipe diameter on phase split. For this, the data reported by Buell et al. (1994) and Peng et al. (1998) have been selected since they have been reported at inlet conditions (namely phase superficial velocities and pressure at the T-junction) close to the present experiments. The comparisons, shown in Figs. 8 and 9, do not bring out any systematic effect of pipe diameter on split.

Further attempts have been made to evaluate the gas and liquid momentum for the stratified liquid layer in each case. The data on dimensionless liquid height (h/D) as supplied by the workers

Table 1

The flow parameters of the present experimental data for different pressure conditions

#	U_{Ls} (m/s)	U_{Gs} (m/s)	p (kPa)	h/D	Re_L	Re_G	M_L (kg m/s)	U_L (m/s)	M_G (kg m/s)	U_G (m/s)
1	0.0055	2.5	131.5	0.1865	114.9	1077.2	1.86	0.0043	12.74	2.88
2	0.0055	2.5	191	0.185	114.9	1563.6	1.87	0.0043	18.51	2.88
3	0.0055	3.5	131.5	0.166	121.8	1478.8	2.55	0.0051	23.3	3.89
4	0.0055	3.5	191	0.151	128.2	2137.1	3.39	0.0058	32.77	3.83
5	0.0055	4.9	131.5	0.135	136.0	2070.2	4.69	0.0069	43.6	5.33
6	0.0055	4.9	191	0.121	143.7	2994.9	6.38	0.008	61.78	5.26
7	0.0097	2.5	131.5	0.223	182.4	1090.9	3.39	0.0058	13.94	3.01
8	0.0097	2.5	191	0.223	182.4	1583.4	3.39	0.0058	20.25	3.01
9	0.0097	3.5	131.5	0.2	193.0	1494.8	4.57	0.0068	25.18	4.05
10	0.0097	3.5	191	0.182	203.3	2156.9	6.02	0.0078	35.05	3.96
11	0.0097	4.9	131.5	0.164	215.3	2086.6	8.22	0.0091	46.2	5.48
12	0.0097	4.9	191	0.148	227.3	3015.3	11.05	0.0105	64.95	5.4

Table 2

The flow parameters for the data of Azzopardi and Memory (1989)

#	U_{Ls} (m/s)	U_{Gs} (m/s)	p (kPa)	h/D	Re_L	Re_G	M_L (kg m/s)	U_L (m/s)	M_G (kg m/s)	U_G (m/s)
1	0.055	8.33	150	0.171	9092	31676	234.5	0.484	159.0	9.4
2	0.055	5.88	300	0.172	9069.2	44729.8	231.3	0.481	158.7	6.6

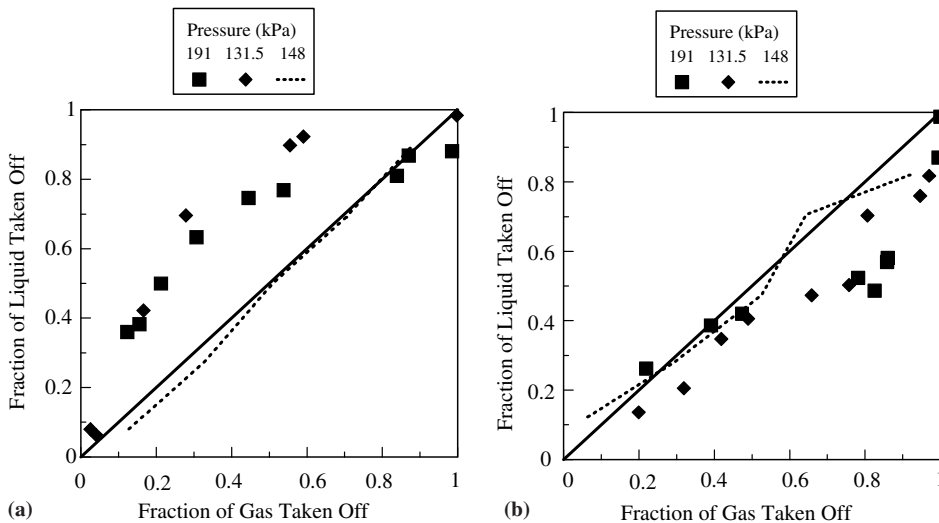

Fig. 8. Comparison of present data with that of Buell et al. (1994). Present data—diameters = 0.005 m, pressures = 131.5 and 191 kPa. Buell et al.—diameters = 0.051 m, pressure = 148 kPa. (a) Present data—gas superficial velocity = 5 m/s, liquid superficial velocity = 0.0097 m/s; Buell et al.—gas superficial velocity = 4.4 m/s, liquid superficial velocity = 0.0094 m/s; (b) Present data—gas superficial velocity = 2.5 m/s, liquid superficial velocity = 0.0097 m/s; Buell et al.—gas superficial velocity = 2.7 m/s, liquid superficial velocity = 0.0094 m/s.

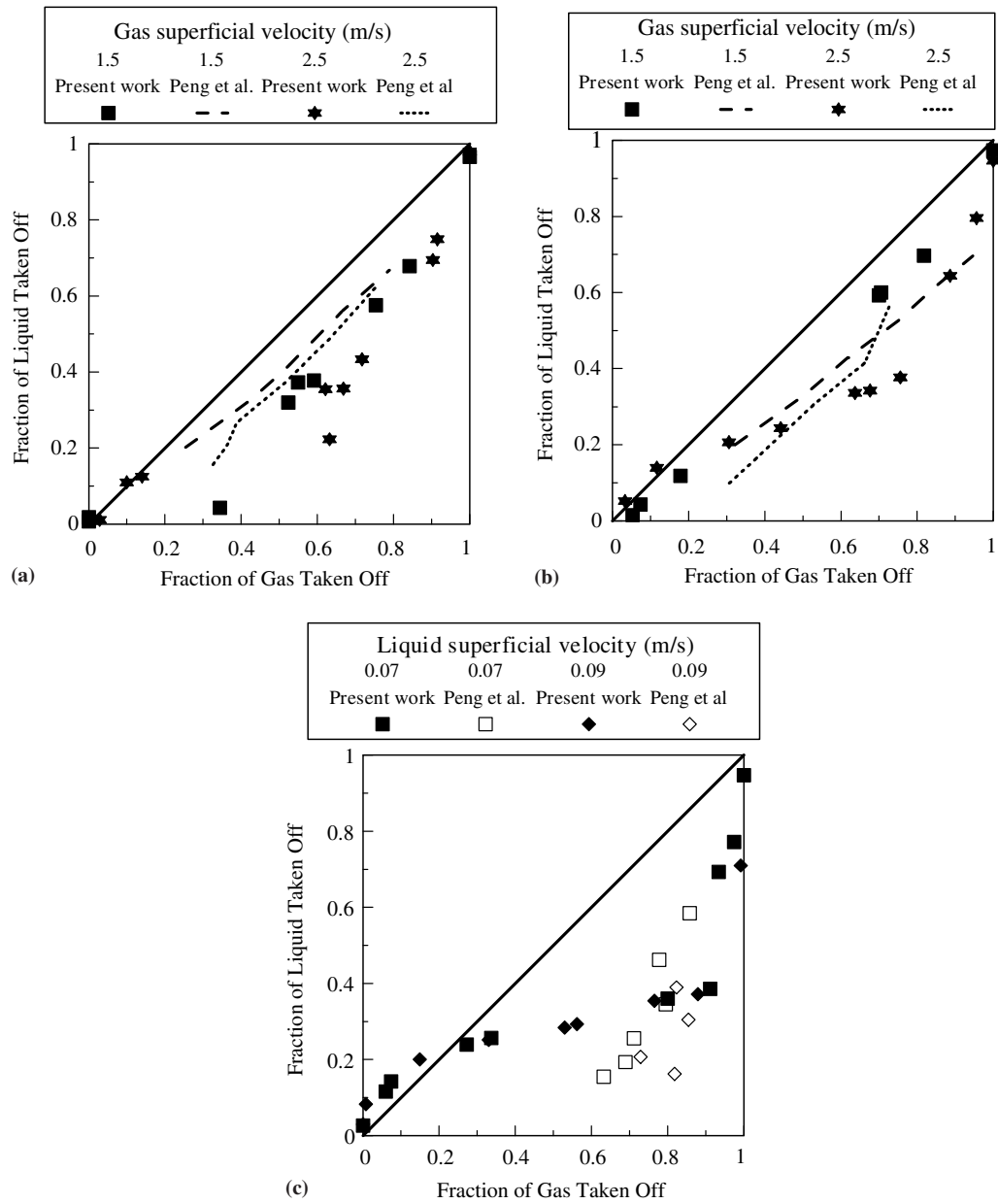

Fig. 9. Comparison of present data with that of Peng et al. (1998). Present data—air/water, diameters = 0.005 m, pressure = 131.5 kPa, Peng et al.—steam/water, diameters = 0.076 m, pressure = 130–150 kPa. (a) Liquid superficial velocity = 0.07 m/s; (b) Liquid superficial velocity = 0.09 m/s; (c) Gas superficial velocity = 5 m/s.

have been used for this purpose and the Taitel and Dukler (1976) model has been adopted for its evaluation in the absence of such information. It is felt that the gas and liquid momentum can explain the trends in phase split for most of the cases and the diameter is important in determining the liquid height.

4. Conclusions

An experimental investigation has been undertaken to understand the phase distribution of a gas–liquid two-phase mixture flowing through a small diameter T-junction. Experiments have been performed at different phase velocities of the two-phases and two constant pressures at the T-junction.

- The results indicate that the liquid fraction in the side arm increases with increasing gas and decreasing liquid superficial velocity under both the pressure conditions. This is in agreement to the observations of the previous researchers in large diameter T-junctions.
- An increase in pressure tends to decrease the fraction of liquid diverted through the branch. This effect has been observed to be more pronounced at higher gas velocities.
- In the present investigation, no significant influence of pipe diameter on phase split could be observed in stratified flow. The pressure in the junction seems to exert a greater influence. An increase in pressure primarily increases the gas momentum. This influences the height of the stratified liquid layer. The changed liquid height has a pronounced effect on the phase distribution.

Acknowledgments

This work was carried out during the stay of PKD and GD at Nottingham in 2000. We would like to thank EPSRC for support for PKD through a Visiting Research Fellowship and the Government of India for support for GD through a BOYSCAST fellowship.

References

- Arrichakran, S., 1990. Two phase flow splitting phenomenon at a regular horizontal side-arm tee. PhD. thesis, University of Tulsa.
- Azzopardi, B.J., 1993. T junctions as phase separators for gas liquid flows: possibilities and problems. *Chem. Eng. Res. Design* 71, 273–281.
- Azzopardi, B.J., 1999. Phase separation at T junctions. *Multiphase Sci. Technol.* 11, 1–143.
- Azzopardi, B.J., Hervieu, E., 1994. Phase separation at junctions. *Multiphase Sci. Technol.* 8, 645–714.
- Azzopardi, B.J., Memory, S.B., 1989. The split of two phase flow at horizontal T-annular and stratified flow. In: 4th International Conference on Multiphase Flow, Nice, France, 19–21 June. BHRA.
- Azzopardi, B.J., Colman, D.A., Nicholson, D., 2002. Plant application of a T junction as a partial phase separator. *Chem. Eng. Res. Design* 80, 87–96.
- Barnea, D., Luninski, Y., Taitel, Y., 1983. Flow pattern in horizontal and vertical two phase flow in small diameter pipes. *Can. J. Chem. Eng.* 61, 617–620.
- Buell, J.R., Soliman, H.M., Sims, G.E., 1994. Two phase pressure drop and phase distribution at a horizontal tee junction. *Int. J. Multiphase Flow* 20, 819–836.
- Fossa, M., Guglielmini, G., 1999. The role of a pipe contraction on the gas–liquid distribution in horizontal intermittent flows. In: Celata, G.P., Di Marco, P., Shah, R.K. (Eds.), *Two-phase Flow Modelling and Experimentation 1999*. Editzione ETS, Pisa, pp. 763–770.
- Hart, J., Hamersma, P.J., Fortuin, J.M.H., 1991. A model for predicting liquid route preference during gas–liquid flow through horizontal branched pipelines. *Chem. Eng. Sci.* 46, 1609–1622.

- Hong, K.C., 1978. Two phase flow splitting at a pipe tee. *J. Petroleum Technol.* 30, 290–296.
- Kline, S.J., McClintock, F.A., 1953. Describing uncertainties in single sample experiments. *Mech. Eng.*, 3–8.
- Lahey, R.T., 1986. Current understanding of phase separation mechanisms in branching conduits. *Nucl. Eng. Design* 55, 145–161.
- Marti, S., Shoham, O., 1997. A unified model for stratified-wavy two-phase flow splitting at a reduced T-junction with an inclined branch. *Int. J. Multiphase Flow* 23, 725–748.
- Moffat, R.J., 1982. Contribution to the theory of single sample uncertainty analysis. *J. Fluids Eng.* 104, 250–260.
- Moffat, R.J., 1988. Describing uncertainties in experimental results. *Exp. Thermal Fluid Sci.* 1, 3–17.
- Muller, U., Reimann, J., 1991. Redistribution of two phase flow in branching conduits: a survey. In: *Proceedings of the International Conference on Multiphase Flows, 91-TSUKUBA, 3, Tsukuba, Japan*, pp. 85–107.
- Oranje, L., 1973. Condensate behavior in gas pipelines is predictable. *Oil Gas J.* 71, 39–44.
- Ottens, M., de Swart, A., Hoefsloot, H.C.J., Hammersma, P.J., 1995. Gas–liquid flow splitting in regular, reduced and impacting T-junctions. *Impaintisitica Italiana* 8, 23–33.
- Peng, F., Shoukri, M., Ballyk, J.D., 1998. An experimental investigation of stratified steam–water flow in junctions. In: *3rd International Conference on Multiphase Flow, Lyon, France, June 8–12*.
- Penmatcha, R., Ashton, P.J.N., Shoham, O., 1996. Two phase flow splitting at a tee junction with an inclined branch. *Int. J. Multiphase Flow* 22, 1105–1122.
- Rea, S., Azzopardi, B.J.A., 2001. The split of horizontal stratified flow at a large diameter T-junction. *Chem. Eng. Res. Design* 79, 470–476.
- Rubel, M.T., Timmerman, B.D., Soliman, H.M., Sims, G.E., Ebadian, M.A., 1988. Phase distribution of high pressure steam water flow at a large diameter tee junction. *J. Fluids Eng.* 116, 592–598.
- Shoham, O., Brill, J.P., Taitel, Y., 1987. Two phase flow splitting in a tee junction-experiment and modeling. *Chem. Eng. Sci.* 42, 2667–2676.
- Stacey, T., Azzopardi, B.J., Conte, G., 2000. The split of annular two phase flow at a small diameter T-junction. *Int. J. Multiphase Flow* 26, 845–856.
- Taitel, Y., Dukler, A.E., 1976. A model for predicting flow regime transitions in horizontal and near horizontal gas–liquid flow. *Am. Inst. Chem. Engrs. J.* 22, 47–55.
- Van Gorp, C.A., Soliman, H.M., Sims, G.E., 2001. The effect of pressure on two phase flow dividing at a reduced tee junction. *Int. J. Multiphase Flow* 27, 571–576.
- Wren, E., Baker, G., Azzopardi, B.J., Jones, R., 2005. Slug flow in small diameter pipes and T-junctions. *Exp. Thermal Fluid Sci.*, in press.